

## Reducing Falls in Construction: Safe Use of Job-made Wooden Ladders

Workers who use job-made wooden ladders risk permanent injury or death from falls and electrocutions. These hazards can be eliminated or substantially reduced by following good safety practices. This fact sheet lists some of the hazards workers may encounter while working on **job-made wooden ladders** and explains what employers and workers can do to reduce injuries. OSHA's requirements for job-made ladders are in Subpart X—Stairways and Ladders of OSHA's Construction standards.

### What is a Job-made Wooden Ladder?

A job-made wooden ladder is a ladder constructed at the construction site. It is not commercially-manufactured. A job-made wooden ladder provides access to and from a work area. It is not intended to serve as a work platform. These ladders are temporary, and are used only until a particular phase of work is completed or until permanent stairways or fixed ladders are installed. A 24-ft. job-made ladder built to the American National Standards Institute (ANSI) A14.4-2009 non-mandatory guidelines is shown below.

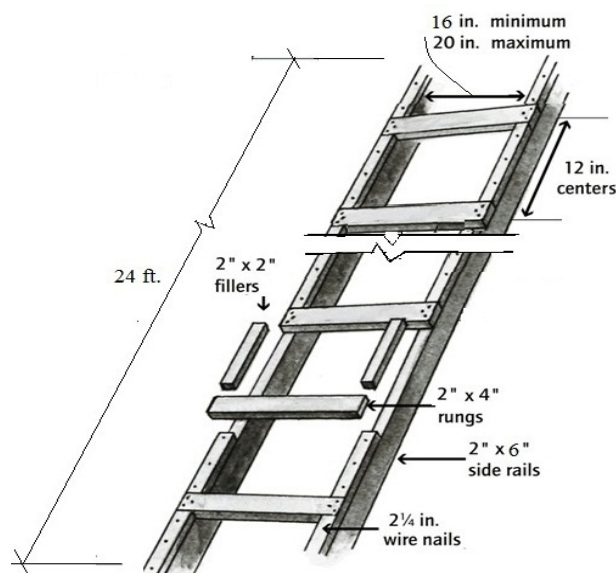

Figure 1: Single-Cleat Ladder

### Training Requirements

Employers must provide a training program for employees using ladders and stairways. The training must enable each worker to recognize ladder-related hazards and to use ladders properly to minimize hazards.

### Constructing a Safe Job-made Wooden Ladder

#### Side rails:

- Use construction-grade lumber for all components.
- Side rails of single-cleat ladders up to 24 ft. (7.3 m) long should be made with at least 2 in. (3.8 cm) x 6 in. (14 cm) nominal stock lumber.
- Side rails should be continuous, unless splices are the same strength as a continuous rail of equal length.
- The width of single-rung ladders should be at least 16 in. (41 cm), but not more than 20 in. (51 cm) between rails measured inside to inside.
- Rails should extend above the top landing between 36 in. (91.5 cm) and 42 in. (1.1 m) to provide a handhold for mounting and dismantling, and cleats must be eliminated above the landing level.
- Side rails of ladders which could contact energized electrical equipment should be made using nonconductive material. Keep ladders free of any slippery materials.
- Only put ladders on a stable and level surface that is not slippery.

#### Cleats:

- Cleats should be equally spaced 12 inches on center from the top of one cleat to the top of the next cleat.
- Cleats should be fastened to each rail with three 12d common wire nails which are nailed directly onto the smaller surfaces of the side rails.
- Making cuts in the side rails to receive the cleats is not advisable.
- Cleats should be at least 1 in. (2.5 cm) x 4 in. (8.9 cm) for ladders 16 ft. (41 cm) to 24 ft. (7.3 m) in length.

### Filler Blocks:

- Filler should be 2 in. (3.8 cm) x 2 in. (3.8 cm) wood strips.
- Insert filler between cleats.
- Nail filler at the bottom of each side rail first. Nail the ends of a cleat to each side rail with three 12d common nails. One nail is placed 1-1/2 inch in from each end of the filler block.
- Nail the next two fillers and cleat, and then repeat. The ladder is complete when filler is nailed at the top of each rail.
- Make all side rails, rungs and fillers before the ladder is assembled.

### Inspecting Ladders

- A competent person must visually inspect job-made ladders for defects on a periodic basis and after any occurrence that could affect their safe use.
- Defects to look for include: structural damage, broken/split side rails (front and back), missing cleats/steps, and parts/labels painted over.
- Ladders should be free of oil, grease and other slipping hazards.



### Safe Ladder Use—DO:

To prevent workers from being injured from falls from ladders, employers are encouraged to adopt the following practices:

- Secure the ladder's base so that it does not move.
- Smooth the wood surface of the ladder to reduce injuries to workers from punctures or lacerations and to prevent snagging of clothing.
- Use job-made wooden ladders with spliced side rails at an angle so that the horizontal distance from the top support to the foot of the ladder is one-eighth the working length of the ladder.
- Ensure that job-made wooden ladders can support at least four times the maximum intended load.
- Only use ladders for the purpose for which they were designed.
- Only put ladders on stable and level surfaces unless secured to prevent accidental movement.
- Ensure that the worker faces the ladder when climbing up and down.
- Maintain a 3-point contact (two hands and a foot, or two feet and a hand) when climbing a ladder.
- Keep ladders free of any slippery materials.
- Maintain good housekeeping in the areas around the top and bottom of ladders.

### Safe Ladder Use—DO NOT:

- Paint a ladder with nontransparent coatings.
- Carry any object or load that could cause the worker to lose balance and fall.
- Subject a job-made wooden ladder to excessive loads or impact tests.

**OSHA standard: 29 CFR 1926 Subpart X—Stairways and Ladders**

**American National Standards Institute standard: ANSI A14.4-1979, ANSI A14.4-2009**

*Employers constructing job-made ladders must follow the ladder requirements set forth in 29 C.F.R. 1926 Subpart X. They are encouraged to consult the non-mandatory guidelines set forth in ANSI A.14.4-1979—Safety Requirements for Job-Made Ladders (referenced in Appendix A to Subpart X of Part 1926—Ladders) and ANSI A.14.4-2009—Safety Requirements for Job-Made Wooden Ladders.*

*State plan guidance: States with OSHA-approved state plans may have additional requirements for avoiding falls from ladders. For more information on these requirements, please visit: [www.osha.gov/dcsp/osp/statesstandards.html](http://www.osha.gov/dcsp/osp/statesstandards.html).*

*Most OSHA offices have compliance assistance specialists to help employers and workers comply with OSHA standards. For details call 1-800-321-OSHA (6742) or visit: [www.osha.gov/htm/RAmap.html](http://www.osha.gov/htm/RAmap.html).*

**This is one in a series of informational fact sheets highlighting OSHA programs, policies or standards. It does not impose any new compliance requirements. For a comprehensive list of compliance requirements of OSHA standards or regulations, refer to Title 29 of the Code of Federal Regulations. This information will be made available to sensory-impaired individuals upon request. The voice phone is (202) 693-1999; teletypewriter (TTY) number: (877) 889-5627.**

**For assistance, contact us. We can help. It's confidential.**



**U.S. Department of Labor  
www.osha.gov (800) 321-OSHA (6742)**